

# 12'-6" (3.810m) BARRIER NDOT F SHAPE

PORTABLE PRECAST  
CONCRETE BARRIER RAIL

## FOR VEHICULAR CONTROL AND CONSTRUCTION SITE SAFETY:

- Reduced Crossover Accidents
- Reduced Liability Exposure
- Reduced Vehicle Damage
- Reduced Traffic Fatalities

## SPECIFICATIONS:

- Approximate Weight per Panel: 6100 lb. (2,774 kg.)
- Laying Length per Panel: 12'-7" (3.835m)
- End Loops accept 1" (25mm) Connecting Pins
- Bridge Pockets have 1 1/4" (32mm) Holes for 1" (25mm) Anchor Rods

## OTHER USES:

- Material Storage Retaining Wall
- Excavation Enclosures
- Barricades
- Security

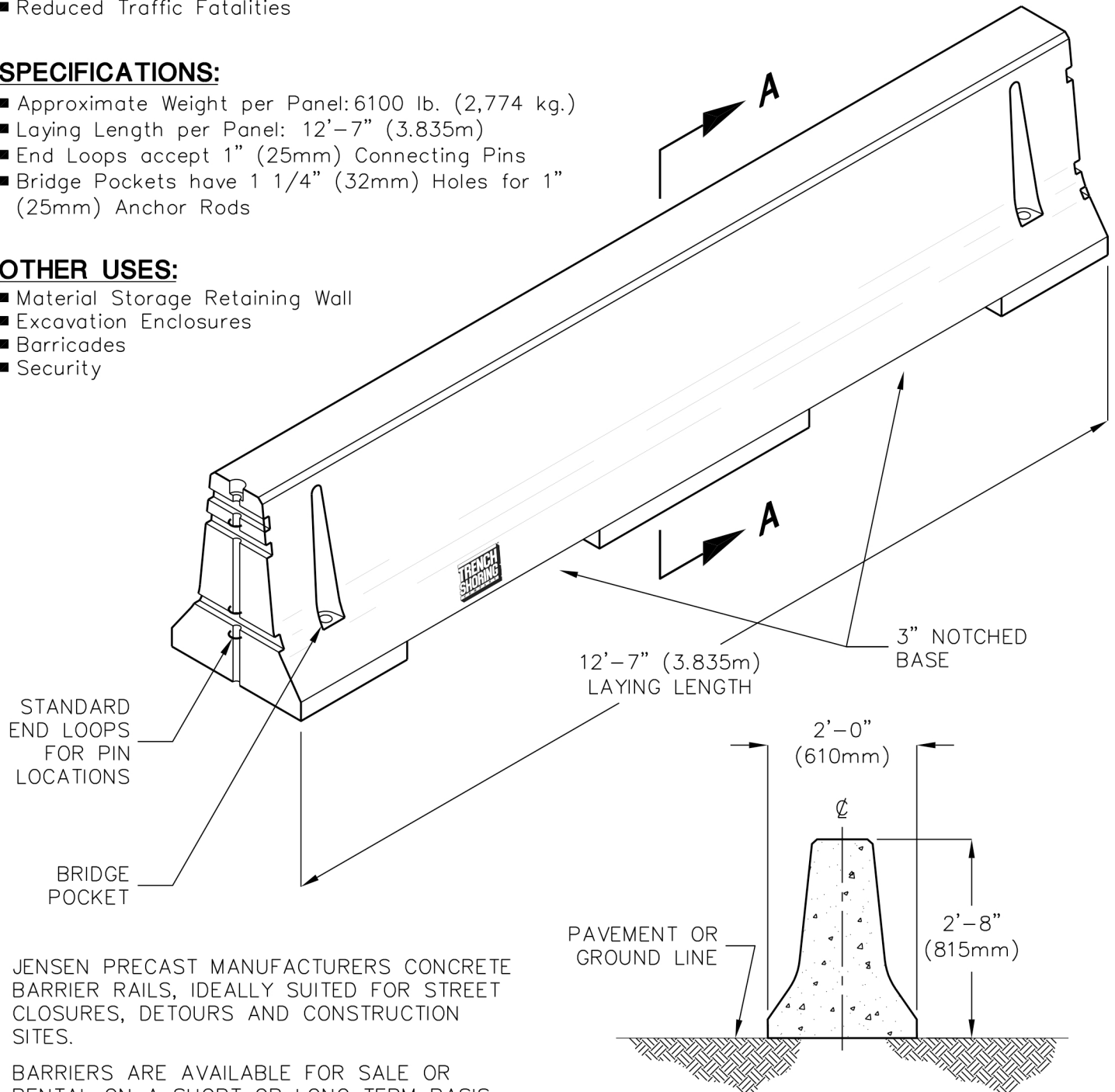

JENSEN PRECAST MANUFACTURERS CONCRETE BARRIER RAILS, IDEALLY SUITED FOR STREET CLOSURES, DETOURS AND CONSTRUCTION SITES.

BARRIERS ARE AVAILABLE FOR SALE OR RENTAL ON A SHORT OR LONG TERM BASIS.

FOR COMPLETE DESIGN AND PRODUCT INFORMATION CONTACT JENSEN PRECAST.